

AMENDMENT NO. 5 (01/2020)

TO

**AIS-113: Code of Practice for Type Approval of Trailers / Semi-trailers of categories T2, T3 and T4 being towed by Motor Vehicles of categories N2 and N3**

**1. Page 1/50, clause No. 1.0**

**Substitute following scope for existing scope of the standard**

**“1.0 SCOPE**

This standard lays down the requirements applicable to Trailers of Category T2, T3, T4 and vehicle carrier trailers, used to transport goods, being towed by motor vehicles of N2 and N3 category.

- Note:** (1) Trailers of category T1 and T5 are not covered in this standard.  
(2) The scope of this standard does not cover design aspects and is restricted to type approval purpose only.  
(3) The scope of the standard does not cover special purpose trailers, vehicle carriers (other than vehicle carrier trailers) and trailers towed by Category M vehicles.”

**2. Page 13/50, clause No. 8.3.1**

**Substitute following text and figures for existing text and figure 3 of clause 8.3.1**

Tractor-Trailer combination shall comply with the maneuverability requirement, as laid down under clause 5.0 of IS12222:2011 as amended from time to time. Figure 3 shall be referred for TCCD limit. In case of vehicle carrier trailers, length of canopy shall not exceed 1000 mm in forward longitudinal direction; front taper shall not exceed 30 degrees and shall have sufficient clearance above the driver cabin for safe operation on roads.

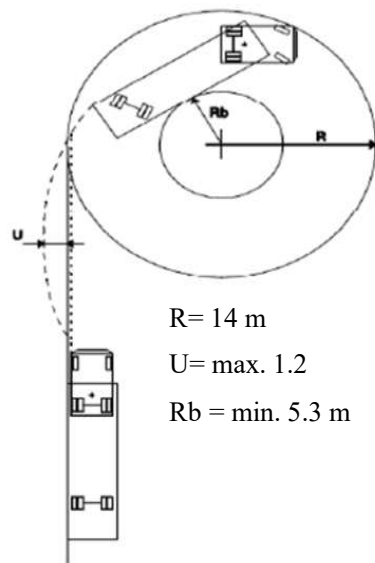

**Figure-3:  
Vehicle Maneuverability**

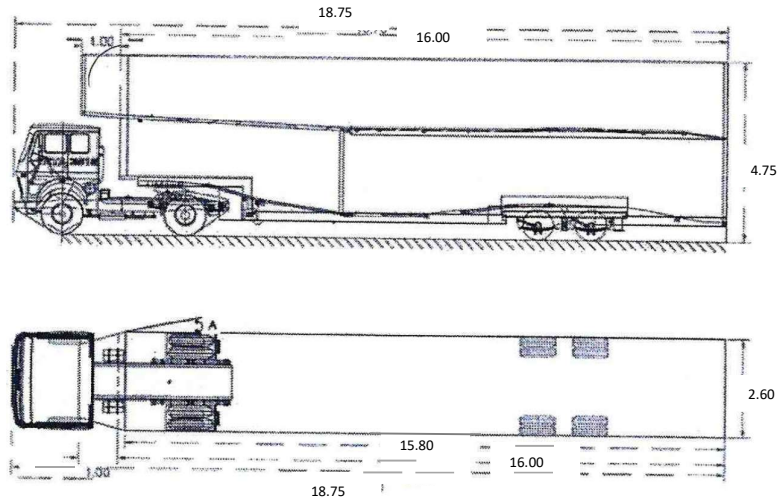

**Figure 4 (for purpose of this standard)**  
**Canopy with an “overhang” of 1m, and a front taper “A”**

PRINTED BY  
 THE AUTOMOTIVE RESEARCH ASSOCIATION OF INDIA  
 P. B. NO. 832, PUNE 411 004  
 ON BEHALF OF  
 AUTOMOTIVE INDUSTRY STANDARDS COMMITTEE  
 UNDER  
 CENTRAL MOTOR VEHICLES RULES - TECHNICAL STANDING COMMITTEE  
 SET-UP BY  
 MINISTRY OF ROAD TRANSPORT & HIGHWAYS  
 (DEPARTMENT OF ROAD TRANSPORT & HIGHWAYS)  
 GOVERNMENT OF INDIA

17<sup>th</sup> January 2020

**AMENDMENT NO. 4 16 September 2016**

**TO**

**AIS-113: Code of Practice for Type Approval of Trailers / Semi-trailers of categories T2, T3 and T4 being towed by Motor Vehicles of categories N2 and N3**

**1. Page 5/50, clause No. 4.4.1, sub-clause ii)**

**Substitute following text for existing text of clause**

“ii) Vehicles used by national or municipal fire brigades for salvaging operations, rescue vehicles, tippers, vehicle with arrangements for a snow plough, road surfacing machine, a gritting device.

**2. Page 6/50, clause No. 5.3**

**Substitute following text for existing text of clause**

“5.3 Installation of Light and Light-signaling devices: The requirements of installation of lighting and light-signaling devices shall be as per AIS-008, as amended from time to time and as specified at Sl. No. 20 of the Table under Rule 124 of the Central Motor Vehicles Rules, 1989, except for Clause No. 6.15 of AIS-008, for the fitment of retro reflector triangle.”

**3. Page 26/50, Annexure -5, Sr. Nos. 2.1 to 2.8.3**

**Substitute following Sr. Nos. 2.1 to 2.8.3 for existing Sr. Nos. 2.1 to 2.8.3**

2.1	Model of the trailer	
2.1.1	Category of Trailer-T2/T3/T4	
2.2	Type & Brief Description of the trailer	
2.3	GVW of the trailer	
2.4	Loads	
2.4.1	Max Permissible FAW of the trailer for Full Trailer	
2.4.2	Unladen FAW of the trailer for Full Trailer	
2.4.3	Max Permissible Load at Kingpin for Semi Trailer	
2.4.4	Unladen Load at Kingpin for Semi Trailer	
2.5	Max Permissible RAW of the trailer	
2.5.1	Unladen RAW of the trailer	
2.6	Compatible Prime mover Configurations	
2.7	Maximum Gross Combination Weight (GCW) of the tractor and trailer	
2.8	Axles :	
2.8.1	Number and Description -	
2.8.2	Front axle- (for Full Trailer only)	

2.8.3	Rear axle -	
-------	-------------	--

**4. Page 27/50, Annexure -5, Sr. No. 2.11.1**

**Substitute following Sr. No. 2.11.1 and 3.3 for existing Sr. No. 2.11.1 and 3.3 and add 3.3.4, 3.3.5**

2.11.1	Front - <b>(for Full Trailer only)</b>	
--------	--	--

3.3	Height (unladen condition), mm	
-----	--------------------------------	--

3.3.4	Height at front end (for full trailer)	
-------	--	--

3.3.5	Height at Kingpin (for semi-trailer)	
-------	--------------------------------------	--

3.3.5.1	Landing gear is fully open	
---------	----------------------------	--

3.3.5.2	At the level where kingpin – fifth wheel mating plate is in horizontal position	
---------	---	--

**5. Page 28/50, Annexure -6,**

**Substitute following Sr. No. 1.8 for existing Sr. No. 1.8**

<b>1.8</b>	<b>Category of Trailer- T2/T3/T4</b>	
------------	--------------------------------------	--

**Substitute following Sr. No. 2.3 for existing Sr. No. 2.3 and add 2.3.4**

2.3	Height (unladen condition), mm	
-----	--------------------------------	--

2.3.4	Height at front end (for full trailer)	
-------	--	--

**Substitute following Sr. No. 3.0 for existing Sr. No. 3.0**

<b>3.0</b>	<b>Height of fifth wheel coupling (king pin) from ground in unladen condition, mm</b>	
------------	---	--

3.1.	Landing gear is fully open	
------	----------------------------	--

3.2.	At the level where kingpin – fifth wheel mating plate is in horizontal position	
------	---	--

**6. Page 31/50, Annexure -6, Sr. No. 7.6**

**Substitute following Sr. No. 7.6 for existing Sr. No. 7.6**

7.6	Make of Tyre	
-----	--------------	--

**7. Page 46/50, Annexure-7, First table**

**Substitute following table for existing table**

Name of the Vehicle Manufacturer & Address :	
--	--

Name of the basic model :			
Name of Variants, if any :			
Place of embossing or etching the trailer identification number details by drawing or pictures may be provided if necessary			
Position of the code for month of production in the Trailer Identification Number			
Position of the code for year of production in the Trailer Identification Number			
Height of the Trailer Identification Number – Min. 7 mm			
Month	Code used	Year	Code used
January	A	2016	16
February	B	2017	17
March	C	2018	18
etc. for 12 months		2019	19
		etc. for 30 years	

**8. Page 46/50, Annexure-7, Trailer Identification plate format**

**Substitute following plate format for existing plate format**

<b>NAME OF THE TRAILER MANUFACTURER</b>	
<b>Type Approval Number:</b>	<b>Trailer Identification Number</b>
<b>Date of Manufacturing Month and Year</b>	<b>Number of Axles &amp; Kerb Weight (kg)</b>
<b>GCW (Semi trailer) / GVW (Full Trailer) (kg)</b>	<b>King Pin Size (Dia (mm) &amp; Load Bearing Capacity (kN)) (Semi-trailer)</b>
<b>Max Permissible - Front Axle Load (kg) - (Full Trailer) / King Pin Load (kg) - (Semi Trailer)</b>	<b>Max Permissible Rear Axle(s) load (kg) -</b>
<b>Tyre Sizes</b>	<b>Payload Capacity of trailer (kg)</b>

PRINTED BY  
THE AUTOMOTIVE RESEARCH ASSOCIATION OF INDIA  
P. B. NO. 832, PUNE 411 004  
ON BEHALF OF  
AUTOMOTIVE INDUSTRY STANDARDS COMMITTEE  
UNDER  
CENTRAL MOTOR VEHICLES RULES - TECHNICAL STANDING COMMITTEE  
SET-UP BY  
MINISTRY OF ROAD TRANSPORT & HIGHWAYS  
(DEPARTMENT OF ROAD TRANSPORT & HIGHWAYS)  
GOVERNMENT OF INDIA

16 September 2016

AMENDMENT NO. 3 16 August 2016

TO

**AIS-113:2013 Code of Practice for Type Approval of Trailers /  
Semi-trailers of categories T2, T3 and T4 being towed by  
Motor Vehicles of categories N2 and N3**

**1. Page 1/50, clause No. 1.0, Note**

**Add following note after 3<sup>rd</sup> note**

“(4) For definitions of vehicle categories N, T and axle related terminologies AIS-053 shall be referred “

**2. Page 1/50, clause No. 3.1 to 3.10**

**Delete clauses 3.1 to 3.10 and substitute following text for existing text of clauses**

“3.1 to 3.10 (Reserved clauses)”

**3. Page 3/50, clause No. 3.30**

**Delete clause 3.30 and substitute following text for existing text of clause**

“3.30 (Reserved clause)”

**4. Page 4/50, clause No. 3.34**

**Substitute following text for existing text of clause**

“**3.34 “Retractable Axle”** means an axle as defined under CMV Rule 93(6)(c), Note (i), 1989.”

**5. Page 4/50, clause No. 3.36**

**Substitute following text for existing text of clause**

“**3.36 “Axle-lift device”** means a device as defined under CMV Rule 93 (6)(c), Note (ii), 1989.”

**6. Page 4/50, clause No. 3.38 to 3.41**

**Delete clauses 3.38 to 3.41 and substitute following text for existing text of clauses**

“3.38 to 3.41 (Reserved clauses)”

**7. Page 8/50, clause No. 7.3**

Substitute “SAE J 844 (November 2004) I/ 2012” for “SAE J 844 (November 2004) I”

**8. Page 13/50, clause No. 8.2.4**

**Substitute following text for existing text**

“8.2.4 T-sign for trailer shall be provided in accordance with IS 9942:1981 except for colour requirements, specified at Sr. No. 4 of the Table under Rule 124 of the Central Motor vehicles Rules, 1989. Colour requirements for T-sign shall be as follows:

(i)The plate shall be painted in white.

(ii)The letter ‘T’ shall be painted in luminous red.”

**9. Page 16/50, clause No. 11.3.1.2, (f)**

**Substitute following text for existing text of sub-clause (f)**

“(f) Change in dimensions (e.g. Length, width, height, wheelbase, etc.).

**10. Page 17/50, clause No. 13.2**

**Substitute following text for existing text**

“13.2 If the changes are in parameters not related to the provisions, no further action need be taken.

If the changes are in parameters related to the provisions, the Testing Agency shall then consider, whether,

- a) the model with the changed specifications still complies with provisions; or
- b) any further verification is required to establish compliance.

**11. Page 19/50, Annexure-1, Sr. No. I. (1) - d)**

**Substitute following row for existing row**

“

d) Wheelbase	YES	NO
--------------	-----	----

”

**12. Page 19/50, Annexure-1, Sr. No. II. (1)**

**Substitute following row for existing row**

“

1.	EMC as per AIS-004 (Part 3) (If fitted with Electronic items like ABS, EVSC, Additional ECU, etc.)	NO	YES
----	--	----	-----

”

**13. Page 21/50, Annexure-2, Flow Chart, Performance/ Compliance Tests, 3<sup>rd</sup> Bullet**

**Substitute following bullet for existing bullet**

“ABS (Part 9) if applicable.”



**14. Page 21/50, Annexure-2, Flow Chart, Performance/ Compliance Tests, 5<sup>th</sup> Bullet**

**Substitute following bullet for existing bullet**

“

- EMC ( If fitted with Electronic items like ABS, EVSC, Additional ECU, etc.)

”

**15. Page 26/50, Annexure-5 and Annexure-6, Technical Specifications**

Add “**Make**” for Axle, landing leg, fifth wheel and Kingpin in Annexure-5 and 6

**16. Page 48/50, Annexure-7, AUTOMOTIVE TRAILER IDENTIFICATION NUMBER**

Substitute “Length of trailer” for “Overall Length”

**17. Page 48/50, Annexure-8, Sr. No. 1**

**Substitute following row for existing row**

1	<b>Changes in trailer configuration</b>	Dynamic tests in unladen condition for brakes in case of changes in C.G. point.
---	---	---

**18. Page 48/50, Annexure-8, Note**

**Substitute following note for existing note**

**Note:** Any other change other than the changes addressed above is considered to have no effect on the performance of the trailer. For considering whether any further verification is required or not, guidelines given in respective standard shall be used.

PRINTED BY  
THE AUTOMOTIVE RESEARCH ASSOCIATION OF INDIA  
P. B. NO. 832, PUNE 411 004  
ON BEHALF OF  
AUTOMOTIVE INDUSTRY STANDARDS COMMITTEE  
UNDER  
CENTRAL MOTOR VEHICLES RULES - TECHNICAL STANDING COMMITTEE  
SET-UP BY  
MINISTRY OF ROAD TRANSPORT & HIGHWAYS  
(DEPARTMENT OF ROAD TRANSPORT & HIGHWAYS)  
GOVERNMENT OF INDIA

16 August 2016

**AMENDMENT NO. 2 4 May 2016**  
**TO**  
**AIS-113:2013 Code of Practice for Type Approval of**  
**Trailers towed by Motor Vehicles of Category N**

**1. Page 9/50, clause No. 7.7**

**Substitute following text for existing text of clause**

Brake palm (pneumatic) couplings may follow guideline of IS 9905:1981 for dimensions. The performance shall be as per IS 10792:1984. If any other type of advanced coupling meeting IS 12358:1988 or others standards are available, the same may be considered.

**2. Page 9/50, clause No. 7.8**

**Substitute following text for existing text of clause**

Compatibility of tractor and trailer must be determined as per clause 8.0 of this Standard.

**3. Page 9/50, clause No. 7.8**

**Substitute following text for existing text of clause**

8.1 Brake System Compatibility: The requirement of braking system compatibility shall be as per IS11852:2001 as amended from time to time, specified under Rule 96 of the Central Motor Vehicle (Amendment) Rules, 1989.

**4. Page 13/50, clause No. 8.3.1**

**Substitute following text for existing text of clause**

Tractor-Trailer combination shall comply with the maneuverability requirement, as laid down under clause 5.0 of IS12222:2011 as amended from time to time. Figure 3 shall be referred for TCCD limit.

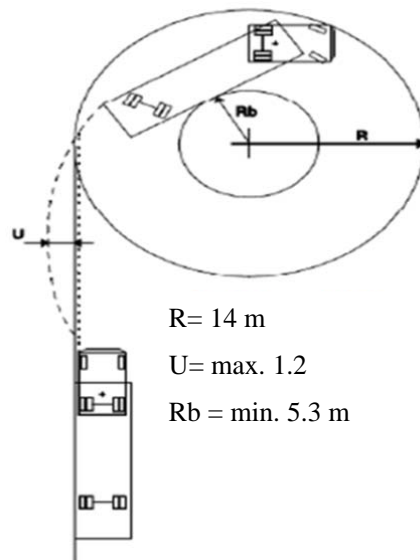

**5. Page 20/50, Annexure -2, clause No. f)**

**Substitute following text for existing text of clause**

- f) The activities involved in the approval and registration of trailers are as indicated in the flow chart below. E-marking consideration shall be as per existing provisions under CMVR.

PRINTED BY  
THE AUTOMOTIVE RESEARCH ASSOCIATION OF INDIA  
P. B. NO. 832, PUNE 411 004  
ON BEHALF OF  
AUTOMOTIVE INDUSTRY STANDARDS COMMITTEE  
UNDER  
CENTRAL MOTOR VEHICLES RULES - TECHNICAL STANDING COMMITTEE  
SET-UP BY  
MINISTRY OF ROAD TRANSPORT & HIGHWAYS  
(DEPARTMENT OF ROAD TRANSPORT & HIGHWAYS)  
GOVERNMENT OF INDIA  
4 May 2016

**Amendment No. 1 October 2013**

**To**

**AIS-113:2013: Code of Practice for Type Approval of Trailers Towed by Motor Vehicles of Category N**

**1. Page I**

**Substitute following title for existing title**

“Code of Practice for Type Approval of Trailers / Semi-trailers of categories T2, T3 and T4 being towed by Motor Vehicles of categories N2 and N3”

**2. Page 1/50, Clause No. 1.0**

**Substitute following scope for existing scope of the standard**

**“1.0 SCOPE**

This standard lays down the requirements applicable to Trailers of Category T2, T3 and T4, used to transport goods, being towed by motor vehicles of N2 and N3 category.

- Note:** (1) Trailers of category T1 and T5 are not covered in this standard.  
(2) The scope of this standard does not cover design aspects and is restricted to type approval purpose only.  
(3) The scope of the standard does not cover special purpose trailers, vehicle carriers and trailers towed by Category M vehicles.”

**3. Page 1/50, Clause No. 3.1**

**Substitute following definition for existing definition**

“Category – T Trailer/ Semi-trailer” means a trailer/ semi-trailer defined in AIS-053 or IS 14272: 2011 towed by a motor vehicle of N2 or N3 Category. This Category –T trailer / semi-trailer directly refers to trailer / semi-trailer already defined under sub-section (39) and (46) of Section (2) of Central Motor Vehicles Act,1988, for all the applicable provisions of the Central Motor Vehicles Act 1988 and the Central Motor Vehicles Rules, 1989.”

**4. Page 1/50, Clause Nos. 3.2 to 3.6**

**Substitute following text for existing text of clauses**

- “3.2 **“T-1 category”** means an automotive trailer as defined under AIS-053/ IS 14272: 2011/ CMV(A)R, 1989.  
3.3 **“T-2 category”** means an automotive trailer as defined under AIS-053/ IS 14272: 2011/CMV(A)R, 1989.  
3.4 **“T-3 category”** means an automotive trailer as defined under AIS-053/ IS 14272: 2011/CMV(A)R, 1989.  
3.5 **“T-4 category”** means an automotive trailer as defined under AIS-053/ IS 14272: 2011/ CMV(A)R, 1989.  
3.6 **“T-5 category”** means an automotive trailer as defined under AIS-053/ IS 14272: 2011/CMV(A)R, 1989.”

**5. Page 7/50, Table 1 : List of guideline standards,**

**Delete row at Sr. No. 4 from the table and renumber subsequent Sr. No.**

**6. Page 8/50, clause No. 7.7**

**Substitute following text for existing text of clause**

Brake palm (pneumatic) couplings shall meet the requirement of IS 9905:1981 for dimensions. The performance shall be as per IS 10792:1984. If any other type of advanced coupling meeting IS 12358:1988 or others standards are available, the same may be considered.

**7. Page 15/50, clause No. 11.3.1**

**Substitute following text for existing text of clause 11.3.1**

Category T 2

PRINTED BY

THE AUTOMOTIVE RESEARCH ASSOCIATION OF INDIA

P. B. NO. 832, PUNE 411 004

ON BEHALF OF

AUTOMOTIVE INDUSTRY STANDARDS COMMITTEE

UNDER

CENTRAL MOTOR VEHICLES RULES - TECHNICAL STANDING COMMITTEE

SET-UP BY

MINISTRY OF ROAD TRANSPORT & HIGHWAYS

(DEPARTMENT OF ROAD TRANSPORT & HIGHWAYS)

GOVERNMENT OF INDIA

October 2013

**AUTOMOTIVE INDUSTRY STANDARD**

**Code of Practice for Type Approval  
of Trailers towed by Motor Vehicles of  
Category N**

PRINTED BY  
THE AUTOMOTIVE RESEARCH ASSOCIATION OF INDIA  
P.B. NO. 832, PUNE 411 004

ON BEHALF OF  
AUTOMOTIVE INDUSTRY STANDARDS COMMITTEE

UNDER  
CENTRAL MOTOR VEHICLES RULES – TECHNICAL STANDING COMMITTEE

SET-UP BY  
MINISTRY OF ROAD TRANSPORT & HIGHWAYS  
(DEPARTMENT OF ROAD TRANSPORT & HIGHWAYS)  
GOVERNMENT OF INDIA

August 2013



## INTRODUCTION

The Government of India felt the need for a permanent agency to expedite the publication of standards and development of test facilities in parallel when the work on the preparation of the standards is going on, as the development of improved safety critical parts can be undertaken only after the publication of the standard and commissioning of test facilities. To this end, the erstwhile Ministry of Surface Transport (MoST) has constituted a permanent Automotive Industry Standards Committee (AISC) vide order No. RT-11028/11/97-MVL dated September 15, 1997. The standards prepared by AISC will be approved by the permanent CMVR Technical Standing Committee (CTSC). After approval, the Automotive Research Association of India (ARAI), Pune, being the secretariat of the AIS Committee, has published this standard. For better dissemination of this information ARAI has published this document on their Web site.

Chapter 7 of AIS-093:2008: “Code of Practice for Construction and Approval of Truck Cabs, Truck Bodies and Trailers” deals with Automotive Trailers have now been deleted.

The trailer manufacturing being an unorganized segment in the country, there is a compelling and long-felt need to upgrade this segment to enhance its efficacy and safety aspects as well.

It would be relevant to mention that the terminology of trailers has been drawn from AIS-053 – “Automotive Vehicles – Types – Terminology” and EEC Directive 97/27/EC – “Masses and dimensions of certain categories of motor vehicles and their trailers”.

As such, from futuristic point of view, any amendment(s) / modification(s) to the definitions therein, would, by default, necessarily reflect in this standard too.

The norms for hydraulic trailers and other small trailers being towed by M category vehicles, are not covered under this standard.

The AISC panel and the Automotive Industry Standards Committee (AISC) responsible for preparation of this standard are given in Annexure-9 and Annexure-10 respectively.

\* \* \* \* \*



## CONTENTS

Clause No.	Details	Page No.
1	Scope	1/50
2	References	1/50
3	Definitions	1/50
4	General Requirements	4/50
5	Electrical System	6/50
6	Applicable Standards for Trailers	7/50
7	Service Brakes for Trailers – Constructional and Functional Requirements	8/50
8	Compatibility between Tractor and Trailer	9/50
9	Safety Critical Items	14/50
10	Interchangeability of Trailers	15/50
11	Type Approval of Trailers	15/50
12	Technical Information to be submitted by the Trailer Manufacturer	17/50
13	Changes in the Technical Specifications already Type Approved	17/50
14	Criteria for Extension of Approval	18/50
15	Conformity of Production (CoP) requirement	18/50

## List of Annexure

Annexure-1	Guidelines for Tests to be conducted for Type Approval of Automotive Trailer	19/50
Annexure-2	Guidelines for Registration of Automotive Trailers	20/50
Annexure-3	Schematic of Trailer Configuration	22/50
Annexure-4	Trailer Categorization	24/50
Annexure-5	Brief Technical Information on Trailers to be submitted by Trailer Manufacturer too Testing Agency	26/50
Annexure-6	Detailed Technical Information on Trailers to be submitted by Trailer Manufacturer to Testing Agency	26/50
Annexure-7	Details of Location of Trailer Identification Number and Code for Month and Year of Manufacture	46/50
Annexure-8	Guidelines for deciding the Test Requirements	48/50
Annexure-9	AISC Panel Composition	49/50
Annexure-10	Automotive Industry Standards Committee Composition	50/50

\* \* \* \* \*

## Code of Practice for Type Approval of Trailers towed by Motor Vehicles of Category N

### 1.0 SCOPE

This standard lays down the requirements applicable to Trailers of Category T, viz. T1, T2, T3 and T4, used to transport goods, being towed by motor vehicles of N2 and N3 category.

- Note:** (1) The category T5 is not covered in this standard.
- (2) The scope of this standard does not cover design aspects and is restricted to type approval purpose only.
- (3) The scope of the standard does not cover special purpose trailers, vehicle carriers and trailers towed by Category M vehicles.

### 2.0 REFERENCES

AIS, IS and other international standards referred in this standard are given in Table-1 ( clause 6.0)

### 3.0 DEFINITIONS

**For the purposes of this standard:**

- 3.1 “Trailers (T Category)” means a non-self propelled vehicle having at least two wheels which on account of its design and technical features is used to transport goods and is intended to be towed by a motor vehicle of Category N; semi-trailer is included in this category.

This definition directly refers to semi-trailers and trailers defined under rule 2 of CMVA under sub-rule (39) and (46).

- 3.2 “**T-1 category**” means an automotive trailer as defined under CMV(A)R, 1989.
- 3.3 “**T-2 category**” means an automotive trailer as defined under CMV(A)R, 1989.
- 3.4 “**T-3 category**” means an automotive trailer as defined under CMV(A)R, 1989.
- 3.5 “**T-4 category**” means an automotive trailer as defined under CMV(A)R, 1989.
- 3.6 “**T-5 category**” means an automotive trailer as defined under CMV(A)R, 1989.
- 3.7 “**Category N**” means a motor vehicle with at least four wheels used for carrying goods which may also carry persons in addition to the goods subject to the conditions specified in clause 3.2 of AIS-053: 2005, as amended from time to time.
- 3.8 “**N1 Category**” means a motor vehicle as defined under CMV (A)R 1989.
- 3.9 “**N2 Category**” means a motor vehicle as defined under CMV (A)R 1989.

- 3.10 **“N3 Category”** means a motor vehicle as defined under CMV (A)R 1989.
- 3.11 **“Semi-trailer”** means a trailer, which is intended to be connected to a motor vehicle and which is so constructed that a portion of it is superimposed on and apart of whose weight is borne by the haulage tractor.
- 3.12 **“Full Trailer”** means a towed vehicle having at least two axles, and equipped with a towing device which can move vertically in relation to the trailer and controls the direction of the front axle(s), but which transmits no significant static load to the towing vehicle.
- 3.13 **“Center Axle Trailer”** means a towed vehicle, equipped with a towing device which cannot move vertically in relation to the trailer) and in which the axle(s) is (are) positioned close to the center of gravity of the trailer (when uniformly loaded) such that only a small static vertical load, not exceeding 10 percent of that corresponding to the maximum mass of the trailer or a load of 1,000 daN (whichever is lesser) is transmitted to the towing vehicle.
- 3.14 **“Load-Dividing Dolly”** is coupled between a tractor and semi-trailer to reduce the load imposed by the semi-trailer on the tractor. It is a truck trailer with one or more axles equipped with a fifth wheel, draw bar, and other parts necessary for its use.
- 3.15 **“Trailer Converter Dolly”** means a truck trailer with one or more axles equipped with a fifth wheel, a drawbar, and other parts necessary to convert a semi-trailer to a full trailer.
- 3.16 **“Low Bed Trailer” (abbreviated as LB)** means a trailer with a flat loading platform but with a swan neck or a wheel arch both at the front and at the rear end. The platform height may be lower than the trailer tyre diameter.
- 3.17 **“Semi Low-bed Trailer” (abbreviated as SL)** means a trailer with a flat loading platform but with a swan neck or with an arch at the front end. The height of the platform may be equal to or more than the trailer tyre diameter.
- 3.18 **“Double Drop Frame Trailer” (abbreviated as DD)** means a trailer where the platform between the wheels is dropped as low as possible to facilitate loading from fitted outboard.
- 3.19 **“Single Drop Frame Trailer” (abbreviated as SD)** means a trailer where the platform is dropped behind the front wheels for loading either by means of a ramp or other suitable method. The rear wheels are usually fitted outboard
- 3.20 **“Flat Bed Trailers” (Abbreviated as FB)** means a trailer with a flat loading platform without any swan necks or wheel arches.

- 3.21 **“Swan Neck (Goose Neck)”** means the raised portion of the trailer beyond the loading platform generally used to accommodate its own wheels or wheels of the towing vehicle.
- 3.22 **“Wheel Arch”** means the raised portion on the platform of a trailer provided to accommodate the vertical travel of its own wheels.
- 3.23 **“Drawbar”** means strut or column like device temporarily attached between the rear of a towing vehicle and the front of the vehicle being towed. Its purpose is to maintain the interval or distance between the two.
- 3.24 **“Drawbar Eye”** means the trailer part of the mechanical coupling of an independent trailer, normally attached to the pintle hook of the tractor.
- 3.25 **“Towing Hook (Pintle Hook)”** means the tractor part of the mechanical coupling of an independent trailer normally attached to the tow eye of the trailer.
- 3.26 **“Fifth Wheel Coupling”** means a device used to connect a tractor to a semi-trailer and to permit articulation between the units. It is generally composed of a lower half, mounted on the tractor, consisting of a trunnion, plate and latching mechanism, for connection with a king pin mounted on the semi-trailer.
- 3.27 **“King Pin”** means the trailer part of the mechanical coupling of a transport trailer normally attached to fifth wheel of the tractor.
- 3.28 **“Towing Capacity”** towing capacity of the draw bar is equal to the total weight of the trailer(s) towed.
- 3.29 **“Trailer Body”** means the structure or fixture especially provided to contain or support the material or property to be transported from one place to other.
- 3.30 **“Group of Axles”** means axles being part of a bogie. A two axle group is called a tandem and a tri-axle group a tri-axle bogie. By convention, a solo axle is considered as a group of one axle.
- 3.31 **“Wheelbase for Semitrailer”** means the distance of the axis of the semi-trailer fifth wheel king pin to the centerline of the non-steering bogie axles, if one or more of the non-steering bogie axles has an axle lift device, then the wheel base with lowered / lifted axle(s), whichever is the longer, is taken into account.
- 3.32 **“Length of Trailer”** means the distance between two vertical planes perpendicular to the longitudinal median plane of the trailer and touching the front and rear of the trailer respectively measured with and without draw bar. The second value being placed in parentheses. Example 5 500 mm (3 700 mm).

**Note:** To determine the length with draw bar, the draw bar is assumed to be located so that the axis of the tow bar eye or coupling head is vertical and lies within the foremost vertical plane.

- 3.33 **“Length of Semi-Trailer”** means the distance between two vertical planes perpendicular to the longitudinal median plane of the trailer and touching the front and rear of the trailer respectively and the distance between kingpin axis and rear end of semi-trailer. The second value being placed in parentheses. Example 10 800 mm (7 800 mm).
- 3.34 **“Retractable Axle”** means an axle which can be raised / lowered by the axle lift device.
- 3.35 **“Loadable Axle”** means an axle the load on which can be varied without the axle being raised by using the axle-lift device.
- 3.36 **“Axle-lift device”** means a device permanently fitted to a vehicle for the purpose of reducing or increasing the load on the axle(s), according to the loading conditions of the vehicle, by raising the wheels clear off the ground / lowering to the ground, in order to reduce wear on the tyres when the vehicle is not fully laden and / or to make starting (moving off) on slippery ground easier for motor vehicles or vehicle combinations, by increasing the load on the driving axle.
- 3.37 **“Special Purpose Vehicles (Trailers)”** means a vehicle of category T, meant for carrying goods and performing a special function, for which special body arrangements and / or equipment are necessary.
- 3.38 **“Tandem Axle”** means any two or two wheel axles spaced by 2440 mm or more (or as specified under CMV(A)R ,1989) from each other.
- 3.39 **“Tandem Bogie”** means two axle wheels spaced by more than 1300 mm upto 2440 mm from each other with defined load sharing ratio.
- 3.40 **“Tridem Axle or Triple Axle ”** means three wheel axle with each axle spaced by more than 3000mm between each other.
- 3.41 **“Tridem Bogie”** means three axle wheels spaced by 3000mm or less with defined load sharing ratio.
- 3.42 **“Extendable trailers”**- A Semi trailer constructed with telescopic chassis to enable the overall length and wheel base to be increased as required

#### 4.0 GENERAL REQUIREMENTS

- 4.1 **Axle Loading:** The permissible load on the axles shall be as per the prescribed limits under the Central Motor Vehicles Rules, 1989 as amended time to time.
- 4.2 **Dimensional Requirements:** The dimensional requirements for trailers shall be as under :
- 4.2.1 **Overall Length:** As defined under Rule 93 of CMV(A)R, 1989

**Note:** The overall length is measured between the fronts of the tractor to the rear most part of the trailer. This excludes any part(s) projecting in front or rear (eg. Towing hooks, bumpers, etc.)

- 4.2.2 **Overall Height:** As defined under Rule 93 of CMV(A)R, 1989
- 4.2.4 **Overall Width :** As defined under Rule 93 of CMV(A)R, 1989
- 4.3 **External Projections:** The requirement for external projections shall be in accordance with IS 13942:1994, as amended from time to time and as specified at Sr. No. 11 of Table under Rule 124 of the Central Motor Vehicles Rules, 1989.
- 4.4 **Rear Under run Protection:** The requirements of Rear under run shall be as per IS 14812: 2005 and as amended from time to time.
- 4.4.1 **Rear Under run Protection device is not required on:**
- i) Vehicles designed with a large clearance above the ground, mainly intended to be used off road.
  - ii) Vehicles used by national or municipal fire brigades for salvaging operations, rescue vehicles, tippers, vehicle with a loose loading platform or with arrangements for a snow plough, road surfacing machine, a gritting device.
- 4.5 **Lateral Under run Protection:** The requirements of lateral under run shall be as per IS 14682:2004 as amended from time to time. Exemptions for fitment of Side Under-run Protection devices may be as follows :
- 4.5.1 Lateral Under run protection is exempted for such vehicles, where body work is incompatible with fitment of such a device.
- 4.5.2 Lateral protection is not however required between tandem or tridem axles if their mutual distance is less than 2.1 m.
- 4.5.3 Trailers with retractable axle need only fulfill the requirements in these points when the axles are in their forward most position. Extension of the axles must not produce a gap in the lateral protection.
- 4.5.4 Trailers with retractable axles and extendable trailers may have lateral protection constituted by a strap under the following conditions:
- (a) The strap is fitted with either an automatic or a manual tensioning device which can be tensioned with a torque wrench.
  - (b) Semi-trailers with retractable axle need not be fitted with lateral protection if the distance from a transverse plane through the centre of the coupling pin in its rearmost position to the centre of the front axle in its most forward position is less than 3.9 m.
- 4.6 **Spray Suppression Systems:** The requirements of spray suppression systems shall be as per AIS-013:2004 and as amended from time to time, as specified at Sr.No.33 of Table under rule 124 of the Central Motor Vehicle Rules, 1989.

**5.0 ELECTRICAL SYSTEMS**

- 5.1 **Automobile Lamps (Bulbs):** The performance requirements of automobile lamps bulbs shall be as per AIS-034 as amended from time to time and as specified at Sr. No. 1 of the Table under Rule 124 of the Central Motor Vehicles Rules, 1989.
- 5.2 **Lighting and Light-signaling Devices:** Performance requirements for lighting and light signaling devices shall be as per AIS-012 as amended from time to time and as specified at Sl. No.20 of the Table under Rule 124 of the Central Motor Vehicles Rules, 1989.
- 5.3 **Installation of Light and Light-signaling devices:** The requirements of installation of lighting and light-signaling devices shall be as per AIS-008 as amended from time to time and as specified at Sl. No. 20 of the Table under Rule 124 of the Central Motor Vehicles Rules, 1989.
- 5.4 **Electrical Coupling:** The electric control line shall conform to ISO 11992-1 and 11992-2:2003 including its amendment 1:2007 and be a point-to-point type using:
- 5.4.1 The seven pin connector according to ISO 7638-1 or 7638-2:2003 or,
- 5.4.2 In the case of systems where the connection of the electric control line is automated, the automated connector shall provide as a minimum the same number of pins [with the same electrical conductivity properties and electrical functionality] as the above mentioned ISO 7638 connector and meet the requirements specified in Sl. No. 22 of Annexure A of this standard

## 6.0 GUIDELINE STANDARDS

The following standards consolidated below may be referred by the trailer manufacturer as general guidelines.

**Table 1 : List of Guideline Standards**

Sr. No	Standard	Title of the Standard
1	IS 8037: 2005	General requirement for transport tractors-trailers (First Revision)
2	IS 8903:1978	Specification for drawbars the trailers of up to 5 tonnes gross mass
3	IS 9760:1981	Dimensions for coupling arrangement between towing vehicle and trailer
4	IS 9905 :1981	Specifications of Pneumatic Couplings between Tractors and Trailers
5	IS 10766:2004	Road Vehicles - Fifth Wheels Interchangeability ( <i>First Revision</i> )
6	IS 12358:1988	Specification for contact type coupling for vacuum and pressure braking systems Connection Between Tractor and Trailer
7	IS 13509:1992	Automotive Vehicles-Towing Vehicles-Mounting of Electrical connections on Rear Cross members.
8	IS 13544:1992	Trailers-mounting of ball bearing turn table-Dimensions
9	IS 13579:1992	Transport trailers-Method of test
10	IS 14880:2000	Commercial Road Vehicles –Drawbars coupling and eye for rigid drawbar strength test
11	IS 7774(Part- 1): 2002	Glossary of terms relating to Transport Tractors and Trailers - Part 1 – Basic Terms (Guideline std.)
12	IS 7774(Part-2): 2003	Glossary of terms relating to Transport Tractors and Trailers - Part 2 - Dimensions. (Guideline Std.)
13	AIS-093:2008	Code of Practice for Construction and Approval of Truck Cabs, Truck Bodies and Trailers.
14	AIS-034:2004	Automobile Lamps.
15	DIN 74324-1 (July1987) (February 1996)	Polyamide tubing for Air Braking Systems- Thermoplastic Tubing-Part 1:Requirements and Testing



16	Or SAE J 844 (November 2004)I	Non-metallic Air Brakes System Tubing.
17	SAE J 702 (November 2008)	Brake and Electrical Connections locations- Truck-Tractor and Trailer.
18	SAE J 695 (December 1998)	Turning ability and off-tracking-Motor Vehicles.

## **7.0 SERVICE BRAKES FOR TRAILERS – CONSTRUCTIONAL AND FUNCTIONAL REQUIREMENTS**

- 7.1 Service brakes must work on all wheels of the automotive trailer and shall be fitted with an Anti-Lock Braking System (ABS).
- 7.2 Brake pipes must be designed and positioned that corrosion is avoided as much as possible.
- 7.3 Brake pipes made of plastic or any other suitable material like polyamide; stainless steel etc., used in compressed air must be strong and durable. This shall comply with the requirements stated in IS 15702:2006. The requirement of strength and durability is considered to have met, if the plastic brake pipes meet the requirements specified in DIN 74324-1-(February 1996) “Air Braking Systems- Thermoplastic Tubing- Part 1 : Requirements and Tests” or SAE J 844 (November 2004) I “Nonmetallic Air Brake System Tubing” as amended from time to time.
- 7.4 In case, if the trailer employs hydraulic system, then flexible hoses on the trailer shall comply with the requirements, as laid down under IS 7079:2008.
- 7.5 The braking system fitted on the trailer including the Anti-lock Braking System (ABS) shall comply with the requirements of IS 11852: 2001 as amended from time to time, specified under Rule 96 of the Central Motor Vehicle (Amendment) Rules, 1989.
- 7.6 Brake and electrical connections and locations for Truck-tractor and truck-Trailer may be as per SAE J 702 (November 2008) as amended from time to time for location of hose connection. This may be used as a guideline. Figure-1 and Figure- 2 may be referred.

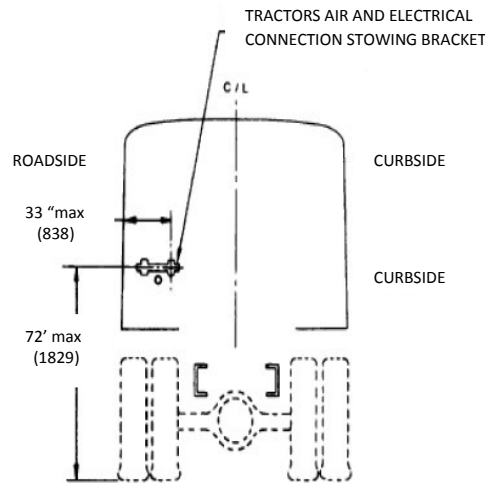

Figure -1

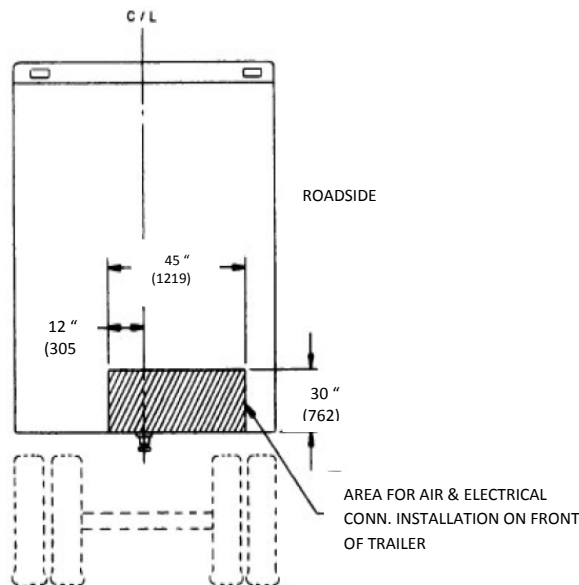

Figure -2

7.7 Brake palm couplings shall meet the requirement of IS 9905:1981 for dimensions. The performance shall be as per IS 10792:1984. If any other type of advanced coupling meeting IS 12358:1988 or others standards are available, the same may be considered.

7.8 Compatibility of tractor and trailer must be determined as per clause 8.1 of this Standard.

## 8.0 COMPATIBILITY BETWEEN TRACTOR AND TRAILER



**Brake System Compatibility:** The requirement of braking system compatibility shall be as per IS 11852: 2001 as amended from time to time, specified under Rule 96 of the Central Motor Vehicle (Amendment) Rules, 1989.

### Guidelines for calculating the trailer brake system requirements - An illustrative Example

- The Actual Brake Force values can be arrived from the Sample Calculation, shown below.

Actual Brake Force on Tractor	Force available at the tractor wheels
Actual Brake Force on Trailer	Force available at the trailer wheels
Total Actual Brake Force	Sum of tractor and trailer forces

- Details required to find out the Brake Forces on Trailer :
  - ✓ Tyre Size / Rolling Radius.
  - ✓ Brake Drum diameter.
  - ✓ Brake Chamber Type. (e.g.: 20 or 24 or 30)
  - ✓ Pressure at Brake Chamber.
  - ✓ Brake Lever Length / Slack Adjuster Length.
  - ✓ Brake Cam's Radius.
  - ✓ Gross Trailer Weight with Load Distribution at King Pin and Trailer Axles.

3Axle Tractor with 3 Axle Trailer –Sample Calculation							
		Units	Front Axle	1 <sup>st</sup> RA	2 <sup>nd</sup> RA	Trailer Axle	
Rolling Radius		m	0.475	0.475	0.475	0.475	
Brake Chamber Size (Area)		Sq In	24	24	24	24	
Pressure		Peff	bar	6.5	6.5	6.5	6.5
SA Lever Length		m	0.2	0.2	0.2	0.2	
Effective Brake Pressure in Brake Chamber		Peff	kPa	650	650	650	650
Brake Factor		k		0.29	0.29	0.29	0.29
Lever Travel	Length	l	m	0.2	0.2	0.2	0.2
<b>Brake Chamber</b>	<b>Effective Area</b>	A	m <sup>2</sup>	0.0155	0.0155	0.0155	0.0154838
Brake Drum Dia		D	m	0.35	0.35	0.35	0.35
Brake Cam's Cam Radius		e	m	0.0127	0.0127	0.0127	0.0127
Wheel Rolling Radius		r	m	0.475	0.475	0.475	0.475
Brake Force (Bn), per axle			N	$P_{eff} \times k \times l \times A \times D \times 2 \times 1000 \times \eta$ $e \times r$			
Brake Force (Bn), per axle				67736	67736	67736	67736
		<b>Actual Brake Force</b>					
Actual Brake Force in Tractor			N	203209			
Actual Brake Force in Trailer			N	203209		Sample Calculation	
Total Actual Brake Force			N	406417			

**Actual Brake Force should always be greater than highest of the Theoretical Brake Forces calculated as shown below:**

- Theoretical brake force can be taken as the Total Weight (GCW). For a 3 axle tractor with 3 axle trailer, for instance, if we calculate

Laden weight of tractor	25000 kg
Laden weight of trailer	24000 kg
Tractor brake force weight	2, 50,000 x 0.8 N
Trailer brake force	2, 40,000 x 0.8 N
Total brake force required	4, 90,000 x 0.8 N

Where 0.8 is the tyre to test surface adhesion as prescribed in the standard.

- The Theoretical Brake Force values can also be found using the formula  $F=ma$ .

$M$  = Maximum laden of tractor or trailer, and  $a = 4.4m/sec^2$ .

For example, considering a 3 axle tractor with 3 axle trailer.  
 Required Force on Tractor:  $m \times a = 25000 \times 4.4 = 1, 10,000$  N  
 Required Force on Trailer:  $m \times a = 24000 \times 4.4 = 1, 05,600$  N  
 Total force required: Tractor force + Trailer force

- Always actual force available at the wheels calculated must be greater than theoretical forces.
- Brake Torque Calculations for Trailer :

Trailer laden Weight	m	32000	kg
Deceleration	a	4.4	m/sec <sup>2</sup>
Force Required to stop the vehicle	$F= m \times a$	140800	N
Force required per Brake (6 brakes in 3 axle vehicle)		23467	N
Rolling Radius (for 11x20 size tyre)	R	0.52	m
Torque required per brake	$T=F \times R$	12203	Nm

- The above calculation can be used to select the suitable Brake Components. (i.e.) For 3 axle trailer with laden weight of 32,000kg and deceleration of 4.4m/sec<sup>2</sup>, the brake torque required per brake is 12203 Nm.
- Hence it is absolutely necessary to select the Brake, which can meet the torque requirement of 12203 Nm.

## 8.2 Communication system compatibility

- 8.2.1 All lighting and signaling devices shall comply with Central Motor Vehicle Rules, 1989 requirements
- 8.2.2 Tell-tale for direction indicators lamps shall be as per clause 6.5.8 of AIS-008 as amended from time to time.
- 8.2.3 Rear Marking Plates shall be as per AIS-089 and Retro-Reflective Markings as per AIS-090 as amended from time to time and as notified under Central Motor Vehicle Rules, 1989.
- 8.2.4 T-sign for trailer shall be provided in accordance with IS 9942:1981, specified at Sr. No. 4 of the Table under Rule 124 of the Central Motor vehicles Rules, 1989.

## 8.3 Maneuverability requirements

- 8.3.1 Tractor-Trailer combination shall comply with the maneuverability requirements, as laid down under clause 5.0 of IS 12222:2011 as amended from time to time.

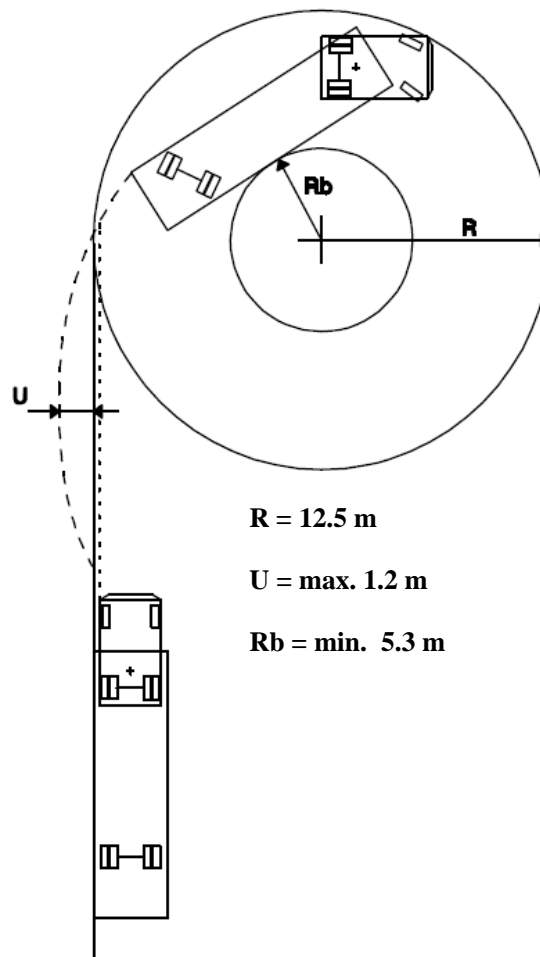

**Figure-3 :**  
**Vehicle Maneuverability**

**9.0 SAFETY CRITICAL ITEMS**

The following components / systems are identified as critical to the safety of the vehicle. Only certified items as per relevant Indian Standards shall be used in the trailer.

- 9.1 **Fifth Wheel Coupling** : The fifth wheel coupling provided on the tractor shall comply with the requirements of AIS-091 and IS 15101 as amended from time to time.
- 9.2 **Fifth Wheel King Pin** : The specifications and other requirements for fifth wheel king pin shall comply with AIS-091 and IS 6763 (Part 1) and (Part 2), as amended from time to time.
- 9.3 **Draw Bar and Draw bar Coupling**: The draw bar and draw bar coupling shall comply with the requirements specified in AIS-091 as amended from time to time.
- 9.4 **Landing Gears** : To comply with requirements stated in AIS-091 and IS :10752 as amended from time to time.
- 9.5 **Tow Hook** : To comply with requirements stated in AIS-091 (Part-1) as amended from time to time.
- 9.6 **Draw Bar Coupling** : Guidelines may be drawn from AIS-091 (Part-1) for trailers above 5 ton gross mass. For trailers of less than 5 ton Gross mass, guidelines may be drawn from IS 8903 as amended from time to time.
- 9.7 **Towing Jaw** : The towing jaw shall comply with requirements stated in AIS-091 (Part-1) as amended from time to time.
- 9.8 **Draw Bar Couplings** : Guidelines for the dimensions of draw bar couplings for interchangeability may be referred from IS 9760, as amended from time to time
- 9.9 **Draw Bar Eye** : The draw bar eye shall meet the requirements of AIS-091 and IS 12807: 1989 for dimensions and IS 13284 for performance as amended from time to time. However, for center axle trailers, the requirements shall be as per IS : 14880. as amended from time to time
- 9.10 **Tyres** : The tyres fitted on semi-trailers and trailers shall comply with the requirements specified under Rule 95 of Central Motor Vehicles Rules, 1989.
- 9.11 **Wheel Rims** : The wheel rims fitted on semi-trailers and trailers shall comply with the requirements of IS 9438 (as amended from time to time) specified under Sr. No. 8 of Rule 124 of Central Motor Vehicles Rules, 1989.

**10.0 INTERCHANGEABILITY OF MECHANICAL COUPLINGS OF SEMI-TRAILERS**

10.1 The interchangeability of mechanical couplings between tractors and trailers/ semi-trailer shall be ensured by verifying compliance to IS 8007 as amended from time to time.

10.2 Where ever mechanical couplings are used for other than those specified under clause 9.0, they shall comply with the requirements specified in AIS-091 ( Part-1) as amended from time to time.

**11.0 TYPE APPROVAL OF TRAILERS**

11.1 The trailer manufacturers shall have their prototype model of trailer approved from any of the test agencies referred in Rule 126 of Central Motor Vehicle Rules, 1989.

11.2 The type approval shall be offered by the testing agencies after necessary compliance to the requirements stated in this standard.

11.2.1 Guidelines for test to be conducted on only trailer and tractor-trailer combination for type approval of automotive trailers are as given in Annexure-1

11.2.2 Guidelines for registration of automotive trailers are given in Annexure-2

11.2.3 Schematic of trailer configuration is described in Annexure-3

11.2.4 Trailer categorization is described in Annexure-4

11.3 Criteria for Type and Variant:-

11.3.1 Categories T 1 and T 2

11.3.1.1 Trailer type:

A 'Trailer type' shall consist of vehicles which have all of the following features in common:

(a) The manufacturer's name.

A change in the legal form of ownership of the company does not require that a new approval has to be granted;

(b) The category;

I The concept of trailer ie. Semitrailer, Full trailer (Drawbar trailer) & Centre axle trailer

(c) The following aspects of construction and design:

(i) The design and construction of the essential constituent elements forming the chassis;

(ii) The design and construction of the essential constituent elements forming the body structure in the case of a self-supporting body;

(d) The number of axles;

11.3.1.2 Variant:

A 'variant' within a vehicle type shall group the vehicles which have all



of the following construction features in common:

- (a) The kind of bodywork (Flat bed, single drop, double drop, box body, semi low bed, tipping type etc.)
- (b) The type of braking system (e.g. unbraked/inertia/power).
- (c) The technically permissible maximum laden mass;
- (d) The concept of the suspension (air, steel or rubber suspension, torsion bar or other);
- (e) The concept of the drawbar (triangle, tube or other).
- (f) Change in dimensions.

11.3.2. Categories T 3 and T 4 :

11.3.2.1 Trailer type :

A 'Trailer type' shall consist of vehicles which have all of the following features in common:

- (a) The manufacturer's name.  
A change in the legal form of ownership of the company does not require that a new approval has to be granted;
- (b) The category;  
I The concept of the trailer i e. Semitrailer, Full trailer (Drawbar trailer) & Centre axle trailer
- (c) The following aspects of construction and design:
  - (i) The design and construction of the essential constituent elements forming the chassis;
  - (ii) The design and construction of the essential constituent elements forming the body structure in the case of trailers with a self-supporting body;
- (d) The number of axles;

11.3.2.2 Variants :

A 'variant' within a vehicle type shall group the vehicles which have all of the following construction and design features in common:

- (a) The kind of bodywork (Flat bed, single drop, double drop, box body, semi low bed, tipping type etc.)
- (b) The concept of the suspensions (steel, air or hydraulic suspension);  
I The following technical features:
  - (i) The capability or not for the chassis to be extendible;
  - (ii) The deck height (normal, low loader, semi-low loader etc.).
- (c) The technically permissible maximum laden mass;

- (d) Axle spacing between consecutive axles forming a group (tandem axles, tridem/ tri axles)
- (e) The definition of the axles in the following respects;
  - (i) Lift axles (number and position);
  - (ii) Loadable axles (number and position);
  - (iii) Steered axle (number and position).
  - (iv) Change in dimensions.

## **12.0 TECHNICAL INFORMATION TO BE SUBMITTED BY TRAILER MANUFACTURER**

- 12.1 The trailer manufacturer shall submit the necessary technical details of the trailers to the test agencies as per Annexure-5 and Annexure-6 of this standard.
- 12.2 The trailer manufacturer shall submit the details of Trailer Identification Number as per Annexure-7 of this standard. It should be punched at the readily accessible position on a part which is normally not likely to be replaced during use.
- 12.3 Other necessary details regarding compliance to the relevant Indian Standards for the safety critical components shall also be submitted to the testing agencies.

## **13.0 CHANGES IN TECHNICAL SPECIFICATIONS ALREADY TYPE APPROVED**

- 13.1 Every modification pertaining to the information declared in accordance with clause 12 shall be intimated by the manufacturer to the certifying agency.
- 13.2 If the changes are in parameters not related to the provisions, no further action need be taken.

If the changes are in parameters related to the provisions, the Testing Agency shall then consider, whether,

- a) the model with the changed specifications still complies with provisions;
- or
- b) any further verification is required to establish compliance.

For considering whether any further verification is required or not, guidelines given in respective standard shall be used.

- 13.3 In case of 13.2 (b), verification for only those parameters which are affected by the modifications needs to be carried out
- 13.4 In case of fulfillment of criterion of clause 13.2 (a) or after results of further verification as per clause 13.2 (b) are successful, the approval of compliance shall be extended for the changes carried out.

**14.0 CRITERIA FOR EXTENSION OF APPROVAL**

The criteria for extension of type approvals would be in accordance with the details given at Annexure-8.

**15.0 CONFORMITY OF PRODUCTION (CoP) REQUIREMENT**

15.1 Whole Vehicle CoP procedure, as and when formulated and notified shall be applicable.

15.2 Trailer approved under this standard shall be so manufactured as to conform to the type approved specifications.

**ANNEXURE-1**

(See 11.2.1)

**GUIDELINES FOR TESTS TO BE CONDUCTED FOR TYPE APPROVAL  
OF AUTOMOTIVE TRAILER**

Sr.No.	Test Description	Only Trailer	Tractor-Trailer Combination
<b>I</b>	<b>VERIFICATION TESTS</b>		
	Dimensional Checks		
1	a) Length	YES	NO
	b) Height	YES	NO
	c) Width	YES	NO
	d) Wheelbase	YES	YES
2	Specified Maximum Axle Weights	YES	NO
3	External Projections	YES	NO
4	Rear Under Run Protection	YES	NO
5	Lateral Under Run Protection	YES	NO
6	Verification of light and Light-Signaling devices	YES	YES
<b>II.</b>	<b>PERFORMANCE TESTS</b>		
1.	EMI (If fitted with Electronic items like ABS, EVSC , Additional ECU, etc)	NO	YES
2.	Brakes	NO	YES
3.	Maneuverability	NO	YES

**ANNEXURE -2**

(See 11.2.2)

**GUIDELINES FOR  
REGISTRATION OF AUTOMOTIVE TRAILERS**

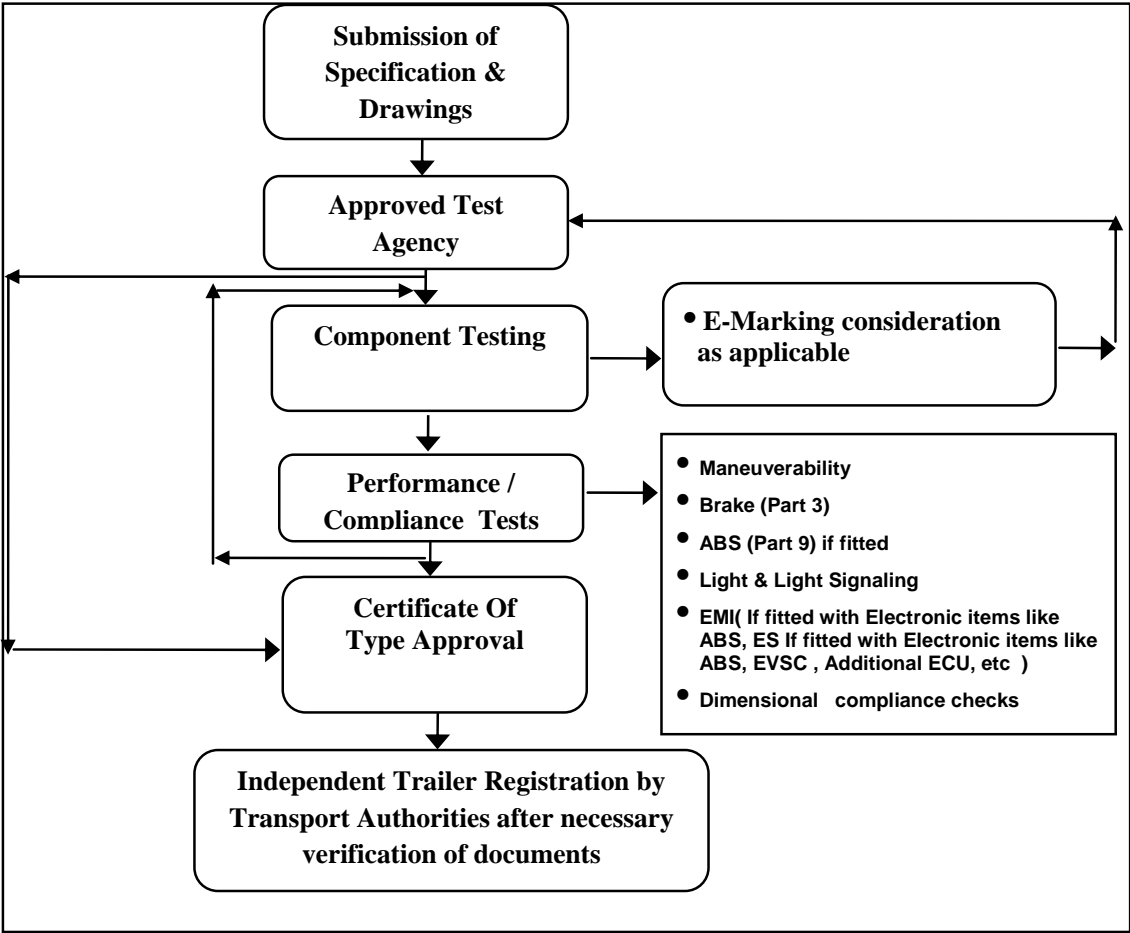

- a) Trailer manufacturer would submit trailer(s) for testing at an approved test agency (as notified under Rule 126 of CMVR). For Type Approval purpose, arrangement of prime mover would have to be made by Trailer manufacturer.
- b) Test agency will issue the type approval certificate to manufacturer, in accordance with procedure laid down under AIS-113.
- c) Thereafter, Trailer manufacturer would submit notarized copies of the Compliance Certificate to the Registering Authorities of respective States, for registration purpose.
- d) Based on the above, said trailer(s) would be registered at respective States, for practical purposes.
- e) With the approval for compliance to AIS-113, by the test agencies as referred under Rule No. 126 of CMVR, no further approval from any other agency will be required.
- f) The activities involved in the approval and registration of trailers are as indicated in the flow chart below.

Flow Chart of Type approval and Registration for trailers

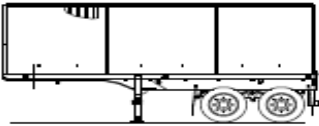
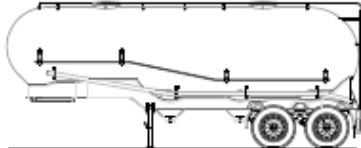

**ANNEXURE-3**  
 (See 11.2.3)  
**SCHEMATIC OF TRAILER CONFIGURATION**

Sr. No.	Name	Diagram
1	Flat Bed	<p align="center">Diagram</p> <p>The diagram shows three side-view schematics of flat bed trailers. The top schematic is labeled 'Single Axle' and shows a single axle with a wheel. The middle schematic is labeled 'Tandem Axle' and shows two axles with wheels. The bottom schematic is labeled 'Tridem Axle' and shows three axles with wheels. Each diagram includes structural details like the frame, suspension, and hitch.</p>
2	Single drop down type	<p align="center">TYPES OF TRAILERS-CLASSIFICATION SEMI LOW BED-SINGLE DROP DOWN TYPE</p> <p>The diagram shows three side-view schematics of single drop down type trailers. The top schematic is labeled 'Single Axle' and shows a single axle with a wheel. The middle schematic is labeled 'Tandem Axle' and shows two axles with wheels. The bottom schematic is labeled 'Tridem Axle' and shows three axles with wheels. Each diagram includes structural details like the frame, suspension, and hitch.</p>
3	Double drop down type(well bed)	<p align="center">TYPES OF TRAILERS-CLASSIFICATION SEMI LOW BED-DOUBLE DROP</p> <p>The diagram shows three side-view schematics of double drop down type (well bed) trailers. The top schematic is labeled 'Single Axle' and shows a single axle with a wheel. The middle schematic is labeled 'Tandem Axle' and shows two axles with wheels. The bottom schematic is labeled 'Tridem Axle' and shows three axles with wheels. Each diagram includes structural details like the frame, suspension, and hitch.</p>

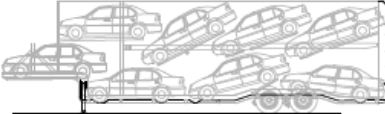
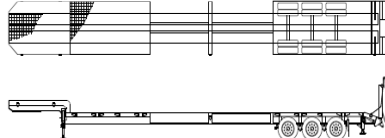
<b>Sr. No.</b>	<b>Name</b>	<b>Diagram</b>
4	Monocoque (tank type, Van type, Fabricated container type)	<p data-bbox="894 243 1256 260">FABRICATED CONTAINER CLOSED BODY TRAILER</p>  <p data-bbox="932 447 1248 464">MONOCOCK DESIGN (TANK CARRIER)</p> 
5	Tipping type	<p data-bbox="943 684 1040 701">TIPPING TYPE</p> 
6	Others(Vehicle carriers, Extendable trailers, Special vehicles) (for reference only)	<p data-bbox="927 963 1081 980">VEHICLE CARRIER</p>  <p data-bbox="902 1125 1097 1142">EXTENDABLE TRAILER</p> 



**ANNEXURE-4**  
(See 11.2.4)

**TRAILER CATEGORISATION**

**1. Articulated vehicle(Semi-Trailer)**

<b>Basis</b>	<b>Variations</b>							
<b>Type of body work</b>	Flat Bed	Semi-low Bed	Single drop down type	Double drop down type (well bed)	Mono-coque (tank type, Van type, Fabricated container type)	Tipping type	Construction Equipment type (Running gears)	Others
<b>Axles</b>	Single	Tandem	Tridem	Combo				
<b>Wheel base</b>	Variable	To suit 4x2	To suit 6x4					
<b>Front Over Hang</b>	Variable	To suit 4x2	To suit 6x4					
<b>Rear Over Hang</b>	Variable	To suit 4x2	To suit 6x4					
<b>Suspension</b>	Pure Mechanical	Mechanical Leaf spring-Free ended type	Mechanical Leaf spring Shackle type	Inverted leaf spring type	Pneumatic	Hydraulic		
<b>Steering</b>	Non steerable	Forced steerable	Self steerable					
<b>Tyres</b>	Different options							
<b>Dimensions</b>	Length.	Width	Height					
<b>King pin</b>	Size - 50.8 mm	Size - 88.9 mm						
<b>Landing leg</b>	Telescopic Mechanical	Hydraulic type						
<b>Platform construction</b>	Mild steel	Aluminium	Wooden type	Sandwich	Skeletal			
<b>Accessories</b>	Twist locks	Tool box	Spare wheel	lashings	Covering			

## 2. Independent Trailer

Parameters	Models					
<b>Axles</b>	Single/ Single	Single/ Tandem	Single/ Tridem	Tandem/ Tandem	Tandem/ Tridem	Tridem/ Tridem
<b>Wheel base</b>	Variable	To suit 4x2	To suit 6x4			
<b>Front Over Hang</b>	Variable	To suit 4x2	To suit 6x4			
<b>Rear Over Hang</b>	Variable	To suit 4x2	To suit 6x4			
<b>Suspension</b>	Pure Mechanical	Mechanical Leaf spring- Free ended type	Mechanical Leaf spring Shackle type	Inverted leaf spring type	Pneumatic	Hydraulic
<b>Steering</b>	Non steerable	Forced steerable	Self steerable			
<b>Tyres</b>	Different options					
<b>Dimensions</b>	Length	width	height			
<b>Turn table</b>	Ball bearing type	Kingpin type				
<b>Tow eye</b>	40mm	50mm	Position			
<b>Accessories</b>	Twist locks	Tool box	Spare wheel	Lashings	Covering	

**ANNEXURE - 5**  
(See 12.1)

**BRIEF TECHNICAL INFORMATION ON TRAILERS TO BE  
SUBMITTED BY TRAILER MANUFACTURER TO TESTING AGENCY**

<b>1.0</b>	<b>Details of Trailer manufacturer</b>	
1.1	Name & address of the trailer manufacturer or importer	
1.2	Telephone No.	
1.3	Fax. No.	
1.4	E-mail address	
1.5	Contact person	
1.6	Address of the Plant(s)of manufacture	
<b>2.0</b>	<b>General details of the trailer:</b>	
2.1	Model of the trailer	
2.2	Type & Brief Description of the trailer	
2.3	GVW of the trailer	
2.4	FAW of the trailer	
2.5	RAW of the trailer	
2.6	Compatible Prime mover Configurations	
2.7	Maximum Gross Combination Weight ( GCW) of the tractor and trailer	
2.8	Axles :	
2.8.1	Number and Description -	
2.8.2	Front axle-	
2.8.3	Rear axle -	
2.9	Suspension - Type and Description:	
2.9.1	Front -	
2.9.2	Rear -	
2.10	Tyre – Number and Size :	
2.10.1	Front -	
2.10.2	Rear -	

<b>Manufacturer :</b>	<b>Document No :</b>	<b>Test Agency :</b>	<b>Cert No :</b>
Signature		Signature	
Name	Sheet No	Name	
Designation	Date	Designation	
Designation	Date	Date of Issue	Page No of

2.11	Brake System Description :	
2.11.1	Front -	
2.11.2	Rear -	
3.0	<b>Trailer Dimensions, mm</b>	
3.1	Length	
3.1.1	With draw bar (for independent trailer)	
3.1.2	Without draw bar (for independent trailer)	
3.1.3	Length (in case of semi trailer)	
3.2	Distance between king pin and rear end (Max. length)	
3.3	Height at front end (unladen condition), mm	
3.3.1	Height of floor from ground at rear, mm	
3.3.2	Overall Height at rear, mm	
3.3.3.	Height of draw bar (hinge point on trailer)	
3.4	Width, mm	
3.5	Wheel Track, mm	
3.5.1	Front (in case of draw bar trailer), mm	
3.5.2	Rear, mm	
3.6	Body overhang, mm	
3.6.1	Front (from fifth wheel in case of semi trailer)	
3.6.2	Rear (from the rearmost axle)	
3.7	Wheel base (from fifth wheel king pin in case of semi trailer)	
3.8	Center of gravity (height of CG from ground & distance from one end) Laden/Unladen, if applicable	
3.9	Dimensional drawing No.	
4.0	Others :	
4.1	Colour of the trailer	

<b>Manufacturer :</b>	<b>Document No :</b>	<b>Test Agency :</b>	<b>Cert No :</b>
Signature		Signature	
Name	Sheet No	Name	
Designation	Date	Designation	
Designation	Date	Date of Issue	Page No of

**ANNEXURE - 6**  
(See 12.1)

**DETAILED TECHNICAL INFORMATION ON TRAILERS TO BE  
SUBMITTED BY TRAILER MANUFACTURER TO TESTING AGENCY**

<b>1.0</b>	<b>Details of Trailer manufacturer</b>	
1.1	Name & address of the trailer manufacturer	
1.2	Telephone No.	
1.3	Fax. No.	
1.4	E-mail address	
1.5	Contact person	
1.6	Plant(s)of manufacture	
1.7	Type and Brief Description of Trailer	
<b>2.0</b>	<b>Trailer Dimensions, mm</b>	
2.1	Length	
2.1.1	With draw bar (for independent trailer)	
2.1.2	Without draw bar (for independent trailer)	
2.1.3	Length (in case of semi-trailer)	
2.2	Distance between kingpin and rear end (Max. length)	
2.3	Height at front end (unladen condition), mm	
2.3.1	Height of floor from ground at rear	
2.3.2	Overall Height at rear	
2.3.3.	Height of draw bar (hinge point on trailer)	
2.4	Width, mm	
2.5	Wheel Track, mm	
2.5.1	Front( in case of draw bar trailer)	

<b>Manufacturer :</b>	<b>Document No :</b>	<b>Test Agency :</b>	<b>Cert No :</b>
Signature		Signature	
Name	Sheet No	Name	
		Designation	
<b>Designation</b>	<b>Date</b>	<b>Date of Issue</b>	<b>Page No of</b>

2.5.2	Rear	
2.6	Body overhang, mm	
2.6.1	Front (from fifth wheel in case of semi-trailer)	
2.6.2	Rear (from the rearmost axle)	
2.7	Wheel base (from fifth wheel king pin in case of semi-trailer)	
2.8	Center of gravity (height of CG from ground & distance from one end) Laden/Unladen, If applicable	
2.9	Dimensional drawing No.	
<b>3.0</b>	<b>Height of fifth wheel coupling (king pin) from ground (laden/unladen tractor), mm</b>	
<b>4.0</b>	<b>T-sign (as per IS 9942)</b>	
4.1	Make	
4.2	Identification mark	
<b>5.0</b>	<b>Axles</b>	
5.1	No. of Axles	
5.2	First axle	
5.2.1	Type	
5.3	Second axle	
5.3.1	Type	
5.4	Third axle	
5.4.1	Type	
5.5	Axle spacing (provide drawing)	
<b>6.0</b>	<b>Trailer Weights</b>	
6.1	Unladen weight of the trailer	

<b>Manufacturer :</b>	<b>Document No :</b>	<b>Test Agency :</b>	<b>Cert No :</b>
Signature		Signature	
Name	Sheet No	Name	
		Designation	
<b>Designation</b>	<b>Date</b>	<b>Date of Issue</b>	<b>Page No of</b>

6.2	Total unladen vehicle weight (TUVW)	TUVW	Front axle/Kingpin weight	Rear axle(s) weight	FAW / RAW
6.3	Gross Vehicle Laden Weight (GLW)	GLW	Max. Permissible FAW/Kingpin weight	Max. Permissible RAW	
6.4	Gross Combination Vehicle Weight (GCVW) (Applicable for articulated vehicle)				
6.5	Payload details				
6.5.2	Weight (kg)				
6.5.3	Location details( to be shown in drawing)				
<b>7.0</b>	<b>Tyres</b>				
7.1	No. and arrangement of wheels				
7.1.1	1st axle				
7.1.2	2nd axle				
7.1.3	3rd axle				
7.1.4	Others (for articulated/combination trailer)				
7.2	Tyre type (Radial/cross ply), size & ply rating				
7.3	Rolling radius, mm				
7.3.1	Static				
7.3.2	Dynamic (if data is available)				
7.4	Inflation pressure – Unladen in kg/cm <sup>2</sup> / kPa				

<b>Manufacturer :</b>	<b>Document No :</b>	<b>Test Agency :</b>	<b>Cert No :</b>
Signature		Signature	
Name	Sheet No	Name	
		Designation	
<b>Designation</b>	<b>Date</b>	<b>Date of Issue</b>	<b>Page No of</b>

7.4.1	1st axle	
7.4.2	2nd axle	
7.4.3	3rd axle	
7.4.4 7.5	Other axle(s) Inflation pressure- Laden in kg/cm <sup>2</sup> /kPa	
7.5.1	1st axle	
7.5.2	2nd axle	
7.5.3	Other axle(s)	
7.6	Make	
7.7	Tread Wear Indicator, Provided (Yes/No)	
7.8	Month & Year code of manufacture, Provided (Yes/No)	
7.9	Maximum loading capacity, Provided (Yes/No)	
<b>8.0</b>	<b>Suspension</b>	
8.1	Type and description (Leaf / Air / Semi-pneumatic / Hydraulic)	
8.1.1	Front	
8.1.2	Rear	
8.2	Make	
8.2.1	Front	
8.2.2	Rear	
8.3	Type of spring	
8.4	If leaf spring	
8.4.1	Main spring	
8.4.1.1	Stack height	
8.4.1.2	Width at the center point / stack point	

<b>Manufacturer :</b>	<b>Document No :</b>	<b>Test Agency :</b>	<b>Cert No :</b>
Signature		Signature	
Name	Sheet No	Name	
		Designation	
<b>Designation</b>	<b>Date</b>	<b>Date of Issue</b>	<b>Page No of</b>



8.4.1.3	Thickness at the center point/stack point		
8.4.1.4	Flat length		
8.4.1.5	Free camber		
		Left	Right
8.4.1.6	No. of leaves		
8.4.1.7	No. of spacers		
8.4.2	Auxiliary Spring		
8.4.2.1	Stack height		
8.4.2.2	Width at the center point/stack point		
8.4.2.3	Thickness at the center point/stack point		
8.4.2.4	Flat length		
8.4.2.5	Free camber		
		Left	Right
8.4.2.6	No. of leaves		
8.4.2.7	No. of spacers		
8.5	If air suspension or semi pneumatic		
8.5.1	Ride height		
8.5.2	Suspension stroke		
8.5.3	Size of the air bellows		
8.5.4	Make of air bellows		
8.5.5	Type of Height control valve		
8.5.6	Make of height control valve		
8.6	If Hydraulic suspension		
8.6.1	Size of cylinder		
8.6.2	Ride height of suspension		
8.6.3	Suspension stroke		
8.7	Suspension-Shock absorber		

<b>Manufacturer :</b>	<b>Document No :</b>	<b>Test Agency :</b>	<b>Cert No :</b>
Signature		Signature	
Name	Sheet No	Name	
		Designation	
<b>Designation</b>	<b>Date</b>	<b>Date of Issue</b>	<b>Page No of</b>

8.7.1	Type and Number	
8.7.1.1	Front	
8.7.1.2	Rear	
8.8	Suspension configuration- Single/Tandem/Tridem	
8.9	Any load equalizing device provided	
<b>9.0</b>	<b>Rear Under run Protective device</b>	
9.1	Height of lower edge of the device from the ground, (mm)	
9.2	Width of the device (mm)	
9.3	Drawing of the rear under-run protective device with dimensions. (Including part drawing)	
9.4	Material (Metal/Fiber/etc.)	
<b>10.0</b>	<b>Lateral Protection(Side Guards)</b>	
10.1	Height of the lower edge of the Side Guard.	
10.2	Drawing of the lateral protection device fitted on the vehicle with dimensions	
10.3	Material (Metal/Fiber/etc.)	
<b>11.0</b>	<b>Chassis Frame</b>	
11.1	Type	
11.2	Drawing with dimensions	
11.3	Type of platform	
<b>12.0</b>	<b>Brakes</b>	
12.1	Type and Brief Description	
12.2	Service brakes	

<b>Manufacturer :</b>	<b>Document No :</b>	<b>Test Agency :</b>	<b>Cert No :</b>
Signature		Signature	
Name	Sheet No	Name	
		Designation	
<b>Designation</b>	<b>Date</b>	<b>Date of Issue</b>	<b>Page No of</b>

12.2.1	Name of producer	
12.2.2	Type (Mechanical/hydraulic/air assisted/ vacuum assisted/others)	
12.2.3	Control system & braking wheel	
12.2.4	Schematic layout indicating method of split of brake system, location of valves, reservoirs etc.	
12.3	Anti-Lock braking system Provided (Yes/No)	
12.3.1	If yes, details	
12.3.2	ABS make	
12.4	Electronic Control Unit (ECU)	
12.4.1	Make	
12.4.2	Identification mark	
12.5	Wheel Speed Sensor	
12.5.1	Make	
12.5.2	Identification mark	
12.5.3	No. of sensors used	
12.6	Hydraulic Modulator	
12.6.1	Make	
12.6.2	Identification mark	
12.7	Solenoid Valve	
12.7.1	Make	
12.7.2	Identification mark	
12.7.3	Max. designed pressure, kg/cm <sup>2</sup>	
12.7.4	Max. working pressure, kg/cm <sup>2</sup>	
12.8	Safety lamp provided (Yes/No)	

<b>Manufacturer :</b>	<b>Document No :</b>	<b>Test Agency :</b>	<b>Cert No :</b>
Signature		Signature	
Name	Sheet No	Name	
		Designation	
<b>Designation</b>	<b>Date</b>	<b>Date of Issue</b>	<b>Page No of</b>

12.9	Schematic layout of the ABS system	
12.10	If ASR is used, give details	
12.11	Brake lining (or) Pad	
12.11.1	Nominal Dimensions, (mm) (Length x Width x thickness)	
12.11.1.1	Front wheel	
12.11.1.2	Rear wheel	
12.11.1.3	Others (in case of Tandem axle, give axle wise data)	
12.11.2	Effective area per axle (cm <sup>2</sup> )	
12.11.2.1	Front axle	
12.11.2.2	Rear axle	
12.11.2.3	Others (in case of Tandem axle, give axle wise data)	
12.11.3	Material	
12.11.4	Make and Designation	
12.11.4.1	Front wheel / axle	
12.11.4.2	Rear wheel / axle	
12.11.4.3	Others (In case of Tandem axle provide data for each axle)	
12.11.5	Whether asbestos or asbestos-free?	
12.12	Brake drum or disc	
12.12.1	Effective diameter, mm	
12.12.1.1	Front wheel	
12.12.1.2	Rear wheel	
12.12.1.3	Others (in case of tandem axle or articulated trailers)	
12.12.2	Material (if the braking surface is non ferrous)	
12.12.2.1	Front	

<b>Manufacturer :</b>	<b>Document No :</b>	<b>Test Agency :</b>	<b>Cert No :</b>
Signature		Signature	
		Name	
Name	Sheet No	Designation	
Designation	Date	Date of Issue	Page No of

12.12.2.2	Rear	
12.12.2.3	Others	
12.13	Master cylinder or brake valve	
12.13.1	Make	
12.13.2	Type	
12.13.3	Inner diameter of the master cylinder, mm	
12.13.4	Operating stroke mm	
12.14	Type of supply tank	
12.15	Wheel cylinder diameter, mm	
12.15.1	Front	
12.15.2	Rear	
12.15.3	Others	
12.16	Wheel cylinder type (single acting/double acting)	
12.16.1	Front	
12.16.2	Rear	
12.16.3	Others	
12.17	Booster	
12.17.1	Name of producer	
12.17.2	Type	
12.17.3	Boost ratio	
12.17.4	Size of the booster, mm (diameter)	
12.17.5	Vacuum or air assistance	
12.17.6	Pressure kg/cm <sup>2</sup>	
12.17.6.1	Nominal (P2 as per IS 11852-2001)	
12.17.6.2	Cut in	
12.17.6.3	Cut out	

<b>Manufacturer :</b>	<b>Document No :</b>	<b>Test Agency :</b>	<b>Cert No :</b>
Signature		Signature	
Name	Sheet No	Name	
		Designation	
<b>Designation</b>	<b>Date</b>	<b>Date of Issue</b>	<b>Page No of</b>

12.18	Type of vacuum pump or air compressor			
12.19	Type of pressure regulator			
12.20	No. of tanks			
12.20.1	Tank Capacity, lit.	Description	Capacity	
12.20.1.1	Tank 1			
12.20.1.2	Tank 2			
12.20.1.3	Tank 3			
12.20.1.4	Tank 4			
12.21	Brake Chamber	Front	Rear	Parking
12.21.1	Make and type			
12.21.2	Size, mm			
12.21.3	Internal diameter, mm			
12.21.4	Stroke, mm			
12.22	Slack adjuster – Manual/Automatic			
12.22.1	Make			
12.22.2	Lever length in mm			
12.22.3	Load sensing valve			
12.22.3.1	Make			
12.22.3.2	Model No.			
12.22.4	Set pressure, unladen in kg/cm <sup>2</sup>			
<b>13.0</b>	<b>Safety Critical Components</b>			
13.1	Wheel rim			
13.1.1	Size			
13.1.1.1	1st axle			
13.1.1.2	2nd axle			
	3rd axle			
13.1.1.3	Other axle(s)			
13.1.2	Name of manufacturer			

<b>Manufacturer :</b>	<b>Document No :</b>	<b>Test Agency :</b>	<b>Cert No :</b>
Signature		Signature	
Name	Sheet No	Name	
		Designation	
Designation	Date	Date of Issue	Page No of

13.1.3	Identification mark	
13.1.4	Pitch circle diameter of mounting bolts, mm	
13.1.5	Number of mounting bolts	
13.1.6	Material (Steel/Aluminum alloy etc.)	
13.2	Wheel nut, Wheel cap and Hub cap	
3.2.1	Wheel Nut	
13.2.1.1	Name of manufacturer	
13.2.1.2	Size	
13.2.1.3	No. of nuts Per wheel	
13.2.1.4	Tightening torque	
13.2.2	Wheel cap / wheel disc	
13.2.2.1	Name of manufacturer	
13.2.2.2	Size	
13.2.2.3	Material (Plastic / Metal)	
13.2.2.4	Method of fitment (Press/bolted/others)	
13.2.3	Hub cap	
13.2.3.1	Name of manufacturer	
13.2.3.2	Size	
13.2.3.3	Method of fitment (Press/bolted/others)	
13.3	Fifth wheel coupling	
13.3.1	Size	
13.3.2	Drawings with dimensions	
13.3.3	Compliance to IS 15101 (Yes/No)	
13.4	Fifth wheel king pin	
13.4.1	Size	

<b>Manufacturer :</b>	<b>Document No :</b>	<b>Test Agency :</b>	<b>Cert No :</b>
Signature		Signature	
Name	Sheet No	Name	
		Designation	
<b>Designation</b>	<b>Date</b>	<b>Date of Issue</b>	<b>Page No of</b>

13. 4.2	Drawings with dimensions	
13. 4.3	Compliance to IS : 6763 (Yes/ No)	
13. 5	Draw bar and Draw bar coupling	
13. 5.1	Size	
13. 5.2	Drawings with dimensions	
13. 5.3	Compliance to IS : 13284 (Yes/ No)	
13. 6	Landing gear	
13. 6.1	Size	
13. 6.2	Drawings with dimensions	
13. 6.3	Compliance to IS 10752 (Yes/ No)	
13. 7	Tow hook	
13. 7.1	Size	
13. 7.2	Drawings with dimensions	
13. 7.3	Compliance to IS : AIS-091, Part 1 (Yes/ No)	
13. 8	Towing jaw	
13. 8.1	Size	
13. 8.2	Drawings with dimensions	
13. 8.3	Compliance to IS : AIS-091, Part 1 (Yes/ No)	
13. 9	Draw bar eye	
13. 9.1	Size	
13. 9.2	Drawings with dimensions	
13. 9.3	Compliance to IS :12807 (Yes/ No)	

<b>Manufacturer :</b>	<b>Document No :</b>	<b>Test Agency :</b>	<b>Cert No :</b>
Signature		Signature	
Name	Sheet No	Name	
		Designation	
<b>Designation</b>	<b>Date</b>	<b>Date of Issue</b>	<b>Page No of</b>



13. 10	Turn table	
13. 10.1	Size	
13. 10.2	Drawings with dimensions	
13. 10.3	Compliance to IS :13544 (Yes/No)	
13. 11	Towing devices, if any	
13. 11.1	Type	
13. 11.2	Name of manufacturer	
13. 11.3	Capacity	
13. 12	Coupling devices, if any	
13. 12.1	Name of the manufacturer	
13. 12.2	Identification mark	
13. 12.3	Type of coupling device for mechanical	
13. 12.4	Type of coupling device for electrical	
13. 12.5	Type of coupling device for brake	
13.13	Any other Accessories provided	
13.13.1	Compliance to any Standard	
<b>14.0</b>	<b>Electrical items</b>	
14.1	Rear Fog Lamp :	
14.1.1	Make and Country of origin (if imported)	
14.1.2	Type of lens (Glass / Plastic)	
14.1.3	Identification No. / Part No.	
14.1.4	Number and Colour of Lens	
14.2	Registration Plate lamp :	
14.2.1	Make and Country of origin (if imported)	
14.2.2	Type of lens (Glass / Plastic)	

<b>Manufacturer :</b>	<b>Document No :</b>	<b>Test Agency :</b>	<b>Cert No :</b>
Signature		Signature	
Name	Sheet No	Name	
		Designation	
Designation	Date	Date of Issue	Page No of

14.2.3	Identification No. / Part No.	
14.2.4	Number and colour of Lens	
14.3	Rear Position Lamp	
14.3.1	Make and Country of origin (if imported)	
14.3.2	Type of lens (Glass / Plastic)	
14.3.3	Identification No. / Part No.	
14.3.4	Number and colour of Lens	
14.4	Rear Parking Lamp	
14.4.1	Make and Country of origin (if imported)	
14.4.2	Type of lens (Glass / Plastic)	
14.4.3	Identification No. / Part No.	
14.4.4	Number and colour of Lens	
14.5	Stop lamp (S1 / S2)	
14.5.1	Make and Country of origin (if imported)	
14.5.2	Type of lens (Glass / Plastic)	
14.5.3	Identification No. / Part No.	
14.5.4	Number and colour of Lens	
14.7	Reversing lamp :	
14.7.1	Make and Country of origin (if imported)	
14.7.2	Type of lens (Glass / Plastic)	
14.7.3	Identification No. / Part No.	
14.7.4	Number and colour of Lens	
14.8	Direction indicator Lamp :	
14.8.1	Rear	
14.8.1.1	Make and Country of origin (if imported)	

<b>Manufacturer :</b>	<b>Document No :</b>	<b>Test Agency :</b>	<b>Cert No :</b>
Signature		Signature	
Name	Sheet No	Name	
		Designation	
<b>Designation</b>	<b>Date</b>	<b>Date of Issue</b>	<b>Page No of</b>

14.8.1.2	Type of lens (Glass / Plastic)	
14.8.1.3	Identification No. / Part No.	
14.8.1.4	Number and colour of Lens	
14.8.2	Side	
14.8.2.1	Make and Country of origin (if imported)	
14.8.2.2	Type of lens (Glass / Plastic)	
14.8.2.3	Identification No. / Part No.	
14.8.2.4	Number and colour of Lens	
14.8.3	Type of flasher	
14.9	Hazard warning signal :	
14.9.1	Rear	
14.9.1.1	Make and Country of origin (if imported)	
14.9.1.2	Type of lens (Glass / Plastic)	
14.9.1.3	Identification No. / Part No.	
14.9.1.4	Number and colour of Lens	
14.9.2	Side	
14.9.2.1	Make and Country of origin (if imported)	
14.9.2.2	Type of lens (Glass / Plastic)	
14.9.2.3	Identification No. / Part No.	
14.9.2.4	Number and colour of Lens	
14.10	Reflector :	
14.10.1	Rear	
14.10.1.1	Make and Country of origin (if imported)	
14.10.1.2	Type	
14.10.1.3	Identification No. / Part No.	
14.10.1.4	Number and colour of Lens	

<b>Manufacturer :</b>	<b>Document No :</b>	<b>Test Agency :</b>	<b>Cert No :</b>
Signature		Signature	
Name	Sheet No	Name	
Designation	Date	Designation	
Designation	Date	Date of Issue	Page No of

14.10.1.5	Area	
14.10.1.6	Shape	
14.10.2	Side	
14.10.2.1	Make and Country of origin (if imported)	
14.10.2.2	Type	
14.10.2.3	Identification No. / Part No.	
14.10.2.4	Number and colour of Lens	
14.10.2.5	Area	
14.10.2.6	Shape	
14.11	End – outline marker lamp (Top light)	
14.11.1	Rear	
14.11.1.1	Make and Country of origin (if imported)	
14.11.1.2	Type of lens (Glass / Plastic)	
14.11.1.3	Identification No. / Part No.	
14.11.1.4	Number and colour of Lens	
14.12	Diagram of vehicle indicating location, reference axis, mark of apparent surface, contour of vehicle parts limiting geometric visibility of all lights and light signaling devices, location of extreme outer edges and longitudinal median plane of vehicle including following dimensions in mm.	
14.13	Along width of vehicle-horizontal distance between inner illuminating surfaces, distance between inner illuminating surfaces and outer most part of vehicle and distance between nearest point of illuminating surfaces of indicators and dipped- beam head lamp	
14.14	Along length of vehicle (where applicable)-distance between the transverse plane corresponding to the longitudinal rearmost extremity to center of reference of rear indicators	

<b>Manufacturer :</b>	<b>Document No :</b>	<b>Test Agency :</b>	<b>Cert No :</b>
Signature		Signature	
Name	Sheet No	Name	
		Designation	
<b>Designation</b>	<b>Date</b>	<b>Date of Issue</b>	<b>Page No of</b>

14.15	Heights of highest and lowest point of illuminating surfaces	
14.16	Automotive bulbs :	
14.16.1	Parking Lamp bulb – Rear	
14.16.1.1	Make and Country of origin (if imported)	
14.16.1.2	Designation as per AIS-034	
14.16.2	Direction indicator lamp bulb -rear	
14.16.2.1	Make and Country of origin (if imported)	
14.16.2.2	Designation as per AIS-034	
14.16.3	Direction indicator lamp bulb -side	
14.16.3.1	Make and Country of origin (if imported)	
14.16.3.2	Designation as per AIS-034	
14.16.4	Rear Position Lamp ( tail lamp )Bulb	
14.16.4.1	Make and Country of origin (if imported)	
14.16.4.2	Designation as per AIS-034	
14.16.5	Stop lamp bulb	
14.16.5.1	Make and Country of origin (if imported)	
14.16.5.2	Designation as per AIS-034	
14.16.6	Number plate lamp bulb	
14.16.6.1	Make and Country of origin (if imported)	
14.16.6.2	Designation as per AIS-034	
14.16.7	End out Marker bulb	
14.16.7.1	Make and Country of origin (if imported)	
14.16.7.2	Designation as per AIS-034	
14.16.8	Reversing lamp bulb	
14.16.8.1	Make and Country of origin (if imported)	
14.16.8.2	Designation as per AIS-034	
14.16.9	Stop Lamp Bulb (S3)	

<b>Manufacturer :</b>	<b>Document No :</b>	<b>Test Agency :</b>	<b>Cert No :</b>
Signature		Signature	
Name	Sheet No	Name	
		Designation	
<b>Designation</b>	<b>Date</b>	<b>Date of Issue</b>	<b>Page No of</b>

14.16.9.1	Make and Country of origin (if imported)	
14.16.9.2	Designation as per AIS-034	
14.16.10	Rear Fog Lamp Bulb	
14.16.10.1	Make and Country of origin (if imported)	
14.16.10.2	Designation as per AIS-034	
14.16.11	Side Marker Lamp Bulb	
14.16.11.1	Make and Country of origin (if imported)	
14.16.11.2	Designation as per AIS-034	

<b>Manufacturer :</b>	<b>Document No :</b>	<b>Test Agency :</b>	<b>Cert No :</b>
Signature		Signature	
Name	Sheet No	Name	
		Designation	
<b>Designation</b>	<b>Date</b>	<b>Date of Issue</b>	<b>Page No of</b>

**ANNEXURE-7**  
(See 12.2)

**DETAILS OF LOCATION OF TRAILER IDENTIFICATION NUMBER AND  
CODE FOR MONTH AND YEAR OF MANUFACTURE**

Name of the Vehicle Manufacturer & Address :	
Name of the basic model :	
Name of Variants, if any :	
Place of embossing or etching the trailer identification number details by drawing or pictures may be provided if necessary	
Position of the code for month of production in the Trailer Identification Number	
Position of the code for year of production in the Trailer Identification Number	
Height of the Trailer Identification Number – Min. 7 mm	

Below plate on trailer chassis needs to be permanently fixed near to goose neck portion. In case of any wrong punching, the procedure for making the correction as indicated in AIS-065 shall be followed.

<b>NAME OF THE TRAILER MANUFACTURER</b>	
<b>Type Approval Number :</b>	
<b>Date of Manufacturing Month and Year</b>	<b>Trailer Identification Number</b>
<b>GVW of Trailer (kg)</b>	<b>King Pin load (kg)</b>
<b>Front Axle Load (kg)</b>	<b>Rear Axle load (kg)</b>
<b>Tire Sizes</b>	<b>Payload Capacity of Trailer</b>

**AUTOMOTIVE TRAILER IDENTIFICATION NUMBER**

1	2	3	4	5	6	7	8	9	10	11	12	13	14
Mfr Name			Trailer Abbreviation			Axles	Overall Length	Month	Year		Serial Number		
EXAMPLE													
T	D	L	S	K	T	3	F	K	0	8	1	2	3

**Manufacturers Name:**

It is a three letter code, which can be assigned to respective trailer manufacturer and registered to BIS through ISO. (Or) the respective trailer manufacturer may assign as per his own choice.

**For Overall Length (Feet):**

Sr. No.	Overall Length (Feet)	Code
1)	Upto 20	A
2)	21-30	B
3)	31-40	C
4)	41-50	D
5)	Special	E
6)	Ministry Approved	F

**For Month :** A – January ; B – February ; C- March; D - April ; E- May ; F - June ; G – July ; H - August; J – September ; K – October ; L – November ; M – December.

**ABBREVIATIONS :**

2.1	“Semi-trailer”	SLB SSL SDD SSD SFB SCT SKT
2.2	“Full Trailer”	FLB FSL FDD FSD FFB FCT FKT
2.3	“Center Axle Trailer”	SCT FCT
2.4	“Low Bed Trailer”	LB
2.5	“Semi low-bed trailer”	SL
2.6	“Double drop frame trailer”	DD
2.7	“Single drop frame trailer”	SD
2.8	“Flat Bed trailers”	FB
2.9	Central Axle Trailer”	CT
3.0	“Skeleton Trailer”	KT



## ANNEXURE-8

(See 14.0)

## GUIDELINES FOR DECIDING THE TEST REQUIREMENTS

Sr. No	Parameters and Change	Tests to be conducted
1	<b>Changes in trailer configuration</b>	Dynamic tests for brakes in case of changes in cg point.
2	<b>Change in GVW of trailer</b>	1) Increase in GVW of trailer upto 10% - No additional test is required 2) If increase in GVW is greater than 10%, dynamic test for brakes to be carried out.
3	<b>Changes in axle configuration</b>	Change in number of axles will call for brake test and maneuverability test
4	<b>Changes in wheel base</b>	1) Increase in Wheel base will call for static brake test-(actuation and reaction time) 2) Decrease in Wheel base will call for all dynamic brake test.
5	<b>Changes in suspension (mechanical/hydraulic/air)</b>	No additional test
6	<b>Changes in braking system</b>	All brake test
7	<b>Changes in turn table for full trailer</b>	Maneuverability test
8	<b>Changes in tyres</b>	1) Increase in rolling radius in excess of 5%-all dynamic brake tests. 2) Increase in aspect ratio- All dynamic brake tests. 3) Radial ply to cross ply- All dynamic brake tests.
9	<b>Changes in overall dimensions</b>	Increase in length – Maneuverability

**Note:** Any other change other than the changes addressed above is considered to have no effect on the performance of the trailer.

**ANNEXURE-9**  
(See Introduction)

**AISC PANEL COMPOSITION**

<b>Organization</b>	<b>Representative(s)</b>
The Automotive Research Association of India, Pune	Shri. A. Akbar Badusha (Convener) Shri. Sujit S Chinchwade Shri Gorre Sai Bharadwaja
Transport Commissioner's Office, Mumbai	Shri. V.N. More Shri. Yogesh Bag
M/s. Tata Motors Ltd, Pune	Shri. P. K. Banerjee Shri. Bhole Sharad Shri. Feroz Khan Shri. Mansingh Jagadale
M/s. Snerith Engineers, Chennai	Shri. B. Ramesh
M/s. Mahindra Navistar Automotives Ltd., Pune	Shri. Amar V Bhosale Shri. V.G. Kulkarni
Automotive Components Manufacturers Association (ACMA)	Shri. K.N.D. Nambudiripad
M/s.Jost India Auto Component Pvt. Ltd.	Shri. Pradeep G S Shri. Amit Saram
M/s. Ashok Leyland Ltd., Chennai	Shri. S. Arun Shri. V. Faustino
M/s. Tejas Polymers and Engineers, Bhosari	Shri. Aravind Kale Shri. Tejas Kale
M/s. Daimler India Commercial Vehicles Pvt. Ltd.	Shri. Navin R N Shastri
M/s. AMW Asia	Shri. Vijay Kumar Shri. Nitin Chamaria
M/s. Tata International DLT Pvt. Ltd.	Shri. Ramesh K Gupta
M/s. Haulmaxx Engineering	Shri. Dileep Mammen
M/s. Aditya Auto Engineering Pvt. Ltd.	Shri. B. Gopala Reddy
M/s. DRD Trucks	Shri. Gowri Shankar
M/s. KKTC	Shri. K. Saravanan
M/s. Sidddivinayak Engineers	Shri. Swapnil Sawardelaar
Central Farm Machinery Testing and Training Institute	Shri. C.V. Chimote
Northern Region Farm Machinery Testing and Training Institute	Shri. P. K. Chopra

**ANNEXURE-10**  
(See Introduction)

**COMMITTEE COMPOSITION \***  
**Automotive Industry Standards Committee**

<b>Chairman</b>	
Shri Shrikant R. Marathe	Director, The Automotive Research Association of India, Pune
<b>Members</b>	<b>Representing</b>
Representative from	Ministry of Road Transport & Highways (Dept. of Road Transport & Highways), New Delhi
Representative from	Ministry of Heavy Industries & Public Enterprises (Department of Heavy Industry), New Delhi
Shri S. M. Ahuja	Office of the Development Commissioner, MSME, Ministry of Micro, Small & Medium Enterprises, New Delhi
Shri T. V. Singh	Bureau of Indian Standards, New Delhi
Shri D. P. Saste (Alternate)	Director , Central Institute of Road Transport, Pune
Dr. M. O. Garg	Indian Institute of Petroleum, Dehra Dun
Director	Vehicles Research & Development Establishment, Ahmednagar
Representatives from	Society of Indian Automobile Manufacturers
Shri T. C. Gopalan	Tractor Manufacturers Association, New Delhi
Shri K.N.D. Nambudiripad	Automotive Components Manufacturers Association of India, New Delhi

Member Secretary  
Mrs. Rashmi Urdhwareshe  
Sr. Deputy Director  
The Automotive Research Association of India, Pune

\* At the time of approval of this Automotive Industry Standard (AIS)